

## IP-to-analog TV converter

Teleste Palomino is an IP-to-analog TV converter that provides high quality analog TV signal in various modulation standards. The fully digital design ensures top class performance and operation in every condition.

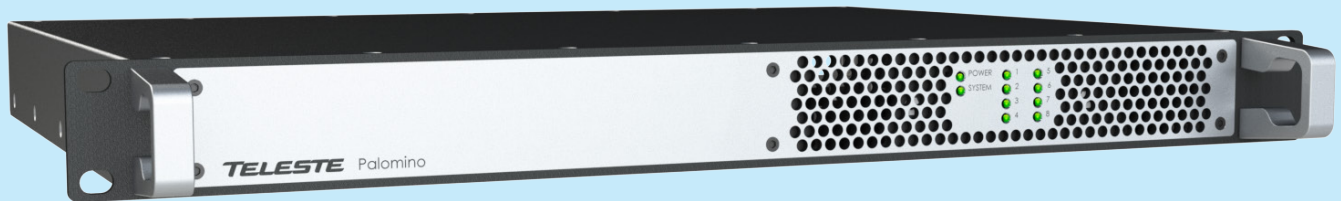

## Features:

- IP streaming input via RJ45 or SFP (redundant)
- ASI input (optional, requires license)
- MPEG decoding
- TV RF modulator (PAL B/G, D/K, SECAM L, D/K, NTSCM)
- Monitoring:
  - Input stream bit rate
  - Detected FEC mode and format
  - Valid, duplicated, out of range, fixed, re-ordered and missing packet counters
  - Input/output payload bit rate
  - TS, video and audio decoding status (sync/no sync)
  - Internal temperature
  - Fan status
  - Power supply status
  - Management
- Redundancy
  - In-chassis power supply redundancy
  - Input stream redundancy (optional)
- Marquee function
  - up to 2500 characters
  - selectable font and background color
  - controllable running speed
- Analog time-sharing function
- Dolby AC3 decoding (optional)
- 4 pcs CI slots for channel descrambling (Palomino CI)
- BISS descrambling

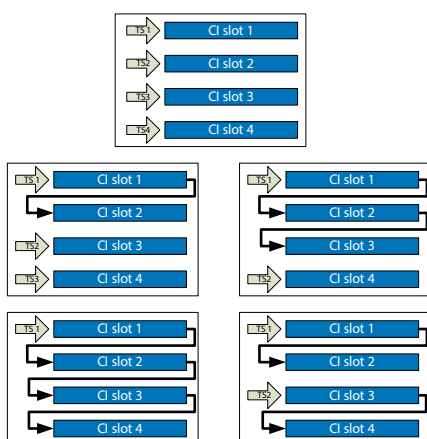

Palomino CI TS routing over CAMs

## High performance with fully digital design

The versatile Palomino can manage 8 channels with bit rates up to 600 Mbit/s per IP input stream in a compact 1 RU housing. The fully digital design ensures high performance operation in every condition.

The unit receives IP streams in SPTS and MPTS formats, demultiplexes and decodes the received channels and finally modulates them to analog channels. Power supply redundancy is standard and also IP input stream redundancy is supported as an optional feature.

## Efficient usage of the output RF frequency range

Each of the 8 RF output channels are individually and independently programmable over the whole RF output frequency range of 47 to 862 MHz., This enables full flexibility and efficient usage of the available channel spectrum by allowing utilization of every frequency slot capable to carry even just a single channel. It also enables high quality video and audio parameters compared to conventional designs.

## Numerous input & output formats

The IP streaming input supports numerous input formats: unicast, multicast and source specific multicasting. The optional redundant IP streaming input supports both electrical and optical connections. The device also has an ASI input as an alternative source.

The Palomino can decode IP streams in SD and HD quality. In case of HD decoding an automatic downscaling is performed. Automatic transcoding of teletext to analog format is supported as well. Numerous audio formats and modes are possible to be decoded and modulated to analog mono and stereo on TV channels.

## Palomino CI - Several options for descrambling

Palomino CI (Common Interface) is attached to the Palomino and adds 4 CI slots to the Palomino unit. The CI slots can be configured very flexibly. Each CI slot can be allocated to its own stream or the CI slots can be daisy chained. This allows numerous routing options for channel descrambling.

## Versatile monitoring possibilities

The device configuration and management is done with an intuitive web user interface, and SNMP and telnet connections are also supported. The unit provides comprehensive set of monitoring and status parameters of the signal and the unit.

## Block diagram

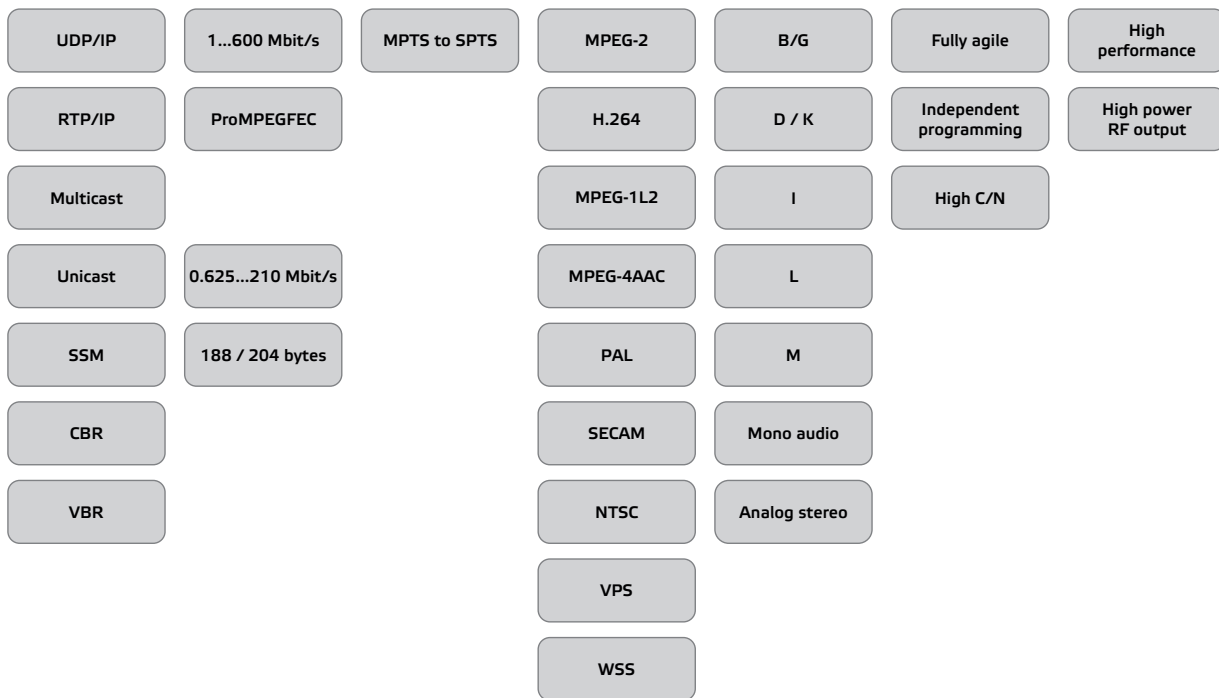
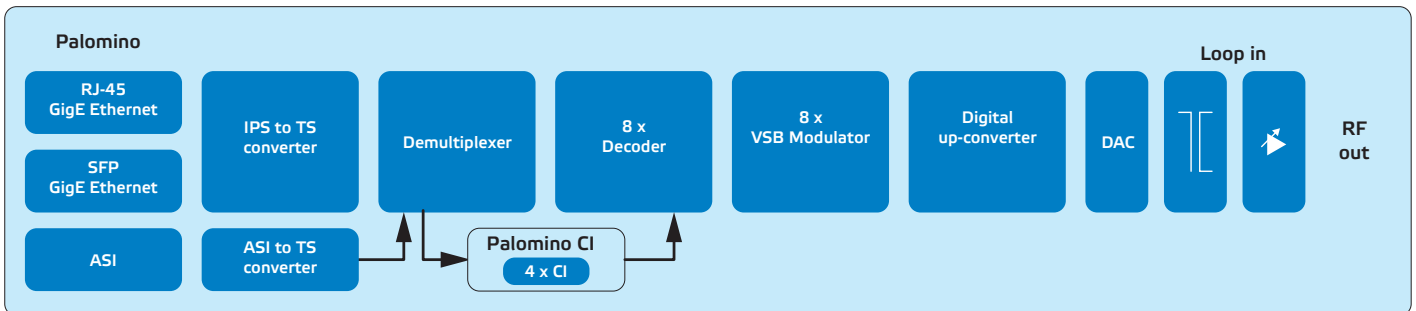

## Rich in features

The Palomino is equipped with plenty of standard and optional features to enhance the usability. With the Marquée function (optional) the on screen text can be edited to suit the needs of a specific channel or program. The Palomino also supports analog time-sharing allowing the operator have two or more different TV channels on one output channel. The time-shared TV channels reserve the same number of channels in Palomino, i.e. 2 time-shared channels take up 2 channels. The embedded optional BISS descrambling can conveniently be managed through the WebUI.

## Safe investment

The Palomino is ideally suited for IP based remote headends, master headends and other kinds of cable networks like hotels or hospitals. Once the analog TV transmission is completely ended, the Palomino can be altered to an IP to QAM with a simple software update, making it a future-proof solution.



# Technical Specifications

<b>IP streaming input</b>		<b>MPEG decoder, Audio</b>	
Connector	RJ-45, SFP slot for optional redundancy	Supported codecs	MPEG-1 Layer II (ISO/IEC 11172-3) MPEG-4 AAC LC (ISO/IEC 14496-3)
RJ-45 standards	10Base-T, 100Base-TX, 1000Base-T	Bit rates	Up to 384 kbit/s MPEG-1 Layer II Up to 192 kbit/s MPEG-4 AAC LC
Link negotiation	Auto sense, auto crossover, auto type	Sampling rates	32, 44.1 and 48 kHz
Frame formats	UDP/IP (RFC 768) or RTP/IP IGMPv3 (RFC 3376) ICMP (RFC 792) (PING) IPv4 (RFC 791)	Audio modes	stereo, mono, dual tone, dual tone with 2 PIDs, joint stereo
FEC	MPEG pro code of practice V2r3	<b>TV modulator</b>	
Stream type	SPTS, MPTS, CBR, VBR	Modulation systems	PAL B/G, PAL D/K, PAL I SECAM D/K, SECAM L NTSC M
Input stream bit rate	1 ... 600 bit/s per stream	<b>Video modulation</b>	
Input bit rate capacity	800 Mbit/s	Video output format	4:3, 16:9
De jittering	120 ms	Video scaling for 4:3	Letterbox, centre cut out
<b>Management port</b>		Video scaling for 16:9	Pillarbox
Connector	RJ-45, 10Base-T, 100Base-TX	<b>Audio modulation</b>	
Protocols	ARP (RFC 826), ICMP (RFC 792) (PING), IPv4 (RFC 768), TCP (RFC 793, RFC 1323) SNMP v1, SNMP v2c, SNMP v3 HTTP 1.1 (RFC 2616), Telnet		Mono sound (4.5, 5.5, 6, 6.5 MHz) Analogue stereo (5.742, 6.742 MHz)
<b>ASI input</b>		Audio level adjustment range	-18 dB ... +20 dB
Input connector	BNC female	Audio level adjustment step	1 dB
Input impedance	75 ohm	<b>RF output</b>	
Input return loss	>= 17 dB	Frequency range	47 ... 862 MHz
Data processing	EN50083-9	Tuning step	10 kHz
ASI transfer format	Continuous, burst	Connector	F female
TS packet format	188, 204 bytes	Impedance	75 ohm
Data rate	0.625 ... 75 Mbit/s	Return loss	>= 18 dB @45 MHz, -1.5dB/octave
<b>TS processing</b>		RF output level range	97 ... 118 dBuV
ITU-T H.222 ISO/IEC 13818-1, ETSI EN 300 468, ETSI TS 101 154		RF output level range (loop mode)	85 ... 106 dBuV
<b>Common Interface (Palomino CI only)</b>		RF output level adjustment step	1 dB
CAM supply voltage	5 V	RF output level stability	± 0.5 dB
CAM power consumption/mobile	5 W max.	Single RF channel adjustment range	-6 ... +3 dB
CAM interface	PCMCIA (EN50221)	Single RF channel adjustment step	0.5 dB
TS bitrate/CAM	75 Mbit/s max.	RF output frequency stability	30 kHz
TS routing over CAMs	4 modules that can be daisy chained	C/N in channel	>= 65 dB
<b>MPEG decoder, Video</b>		RF spurious level 45 ... 862 MHz	>= 60 dBc
Supported codecs	MPEG 2 MP@HL, H264/AVC Level 4.1HP		
Supported colour systems	PAL, SECAM, NTSC		
Subtitling	DVB, teletext		
Signalling	VPS (line 16), WSS (line 23)		
<b>General</b>			
Number of power supplies	2 (redundant)	Enclosure classification	IP21
Power consumption	61 W Palomino 65 W Palomino CI (w/o CAMs)	Operating temperature range	-10...55 °C ambient
Supply voltage	100 ... 240 VAC	EMC	EN50083-2
Connectors	RF-45, SFP slot, BNC female, F female	Safety	EN 60950-1
Dimensions	44 x 448 x 350mm (19" 1RU)	Environment	ETSI EN 300019-1-3 Class 3.1
Weight	6.3 kg Palomino 6.4 kg Palomino CI		